

VENTILATION SOLUTION



ERV

High Efficiency Heat Exchanger

Efficiency and comfort is ensured through the high-efficiency energy recovery central core which recovers energy from the indoor air and transfers it to the fresh incoming air without mixing airstream.

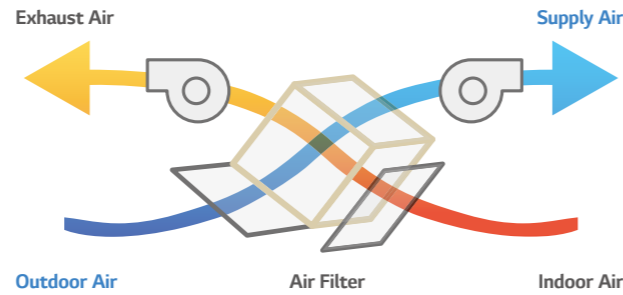

Interlocking with Air Conditioning System

- LG ERV can be interlocked with air conditioners and controlled individually.
- This function can be operated when the system is connected with a remote control.

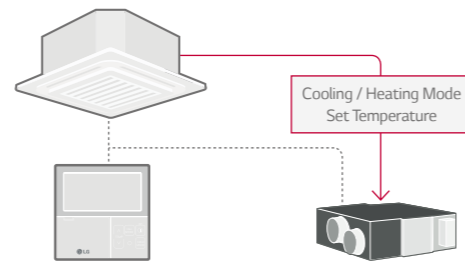

Compulsory Exhausting System

The exhausting system using high static and sirocco fan removes contaminants effectively from indoor air. Supply and exhaust air flows are completely separated in the total heat exchanger, LG ERV can filter out the impurities before supplying outdoor air and make indoor air fresh and healthy.

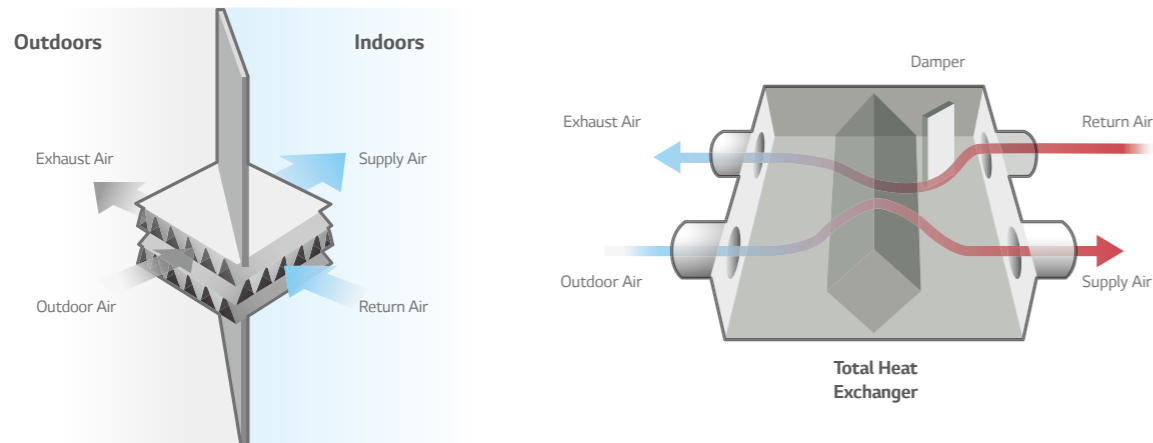

Bypass Ventilation

LG ERV automatically switches the ventilation mode (Enthalpy Heat Exchange Mode / Bypass Mode) according to the indoor / outdoor temperature.

Enthalpy Heat Exchange Mode (Summer / Winter)

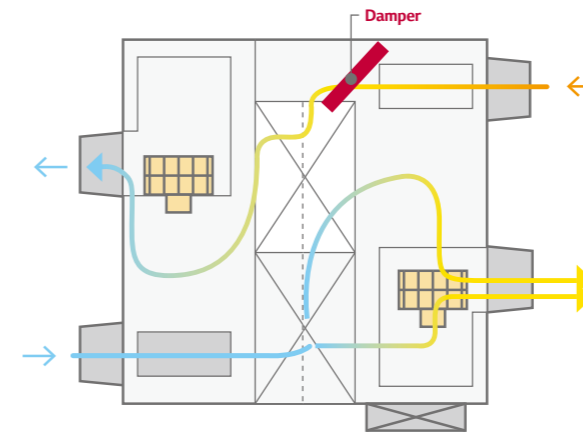

Bypass Mode (Seasonal Change)

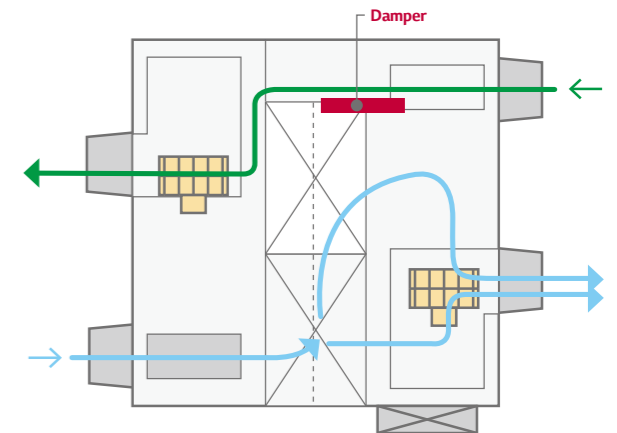

Flexibility of Installation

It's possible to install upside down when you need only one inspection hole.

Normal installation of 2 units

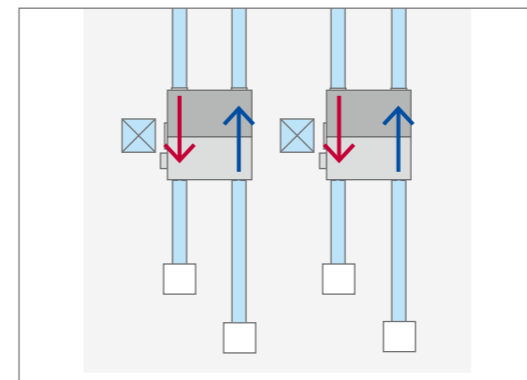

Reverse installation of 1 unit (Left unit)

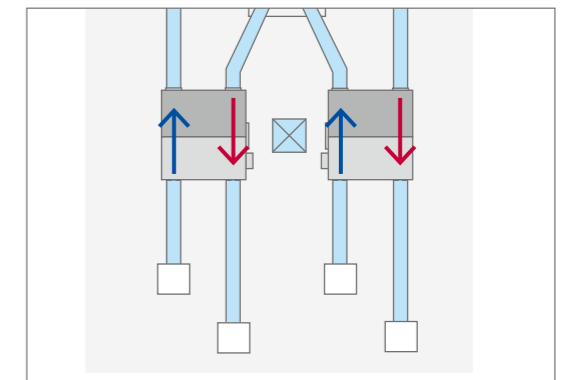

Inspection chamber

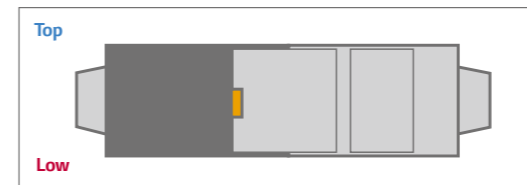

ERV

Easy Cleaning and Filter Change

It is easy and convenient to change and clean the filter.

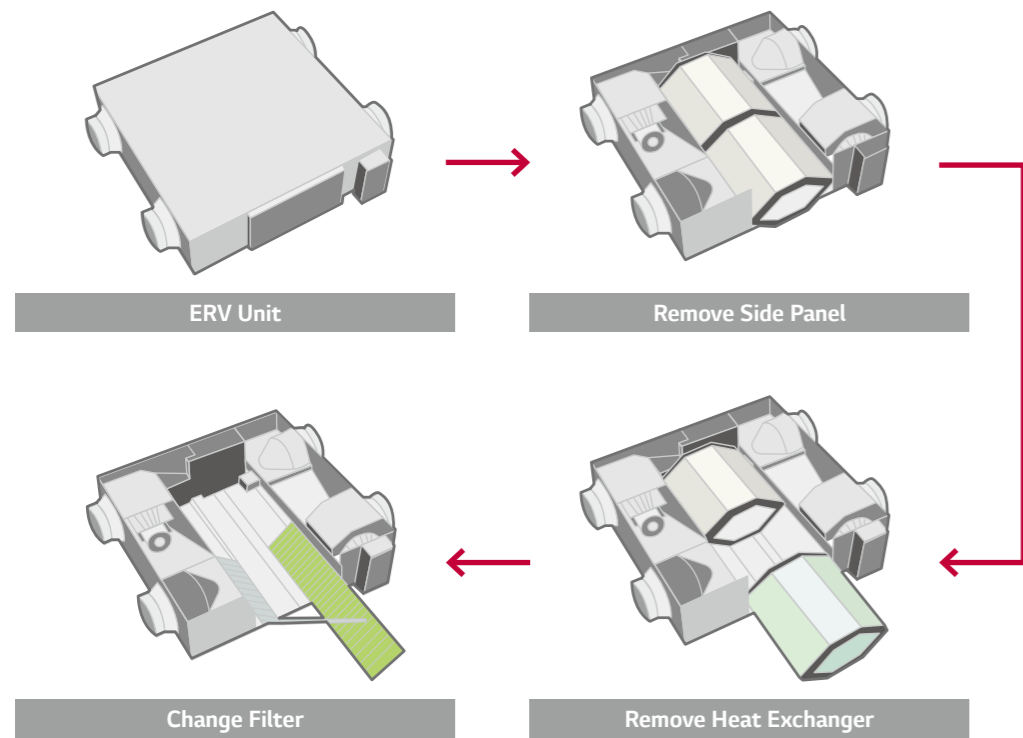

External Static Pressure Control

The high static pressure fan can control the air volume depending on the length of the duct. It is also easy to control the pressure level by using the remote controller for a more flexible duct installation and easier testing.

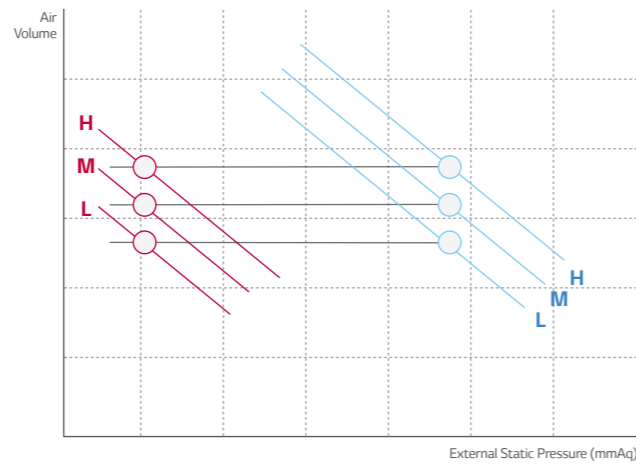

Fast Ventilation Mode

Fast ventilation mode prevents the spread of contaminants under negative indoor pressure, and makes indoor air fresh and comfortable quickly.

Only Exhausting

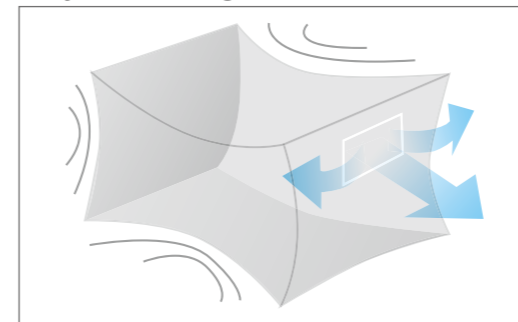

Exhausting operation causes negative indoor air pressure, and cannot fully ventilate.

Fast Ventilation Mode

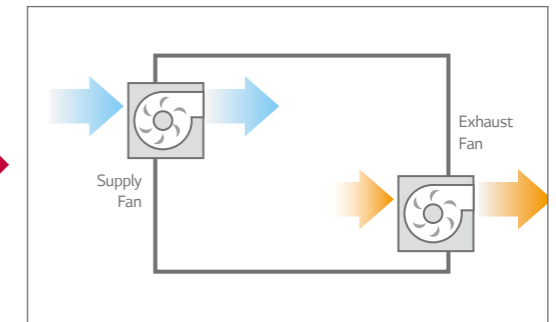

Exhausting and Supplying Simultaneously

CO₂ Concentration Control

Using CO₂ sensor, LG ERV controls exhaust air flow automatically to keep indoor air fresh under settled CO₂ concentration.

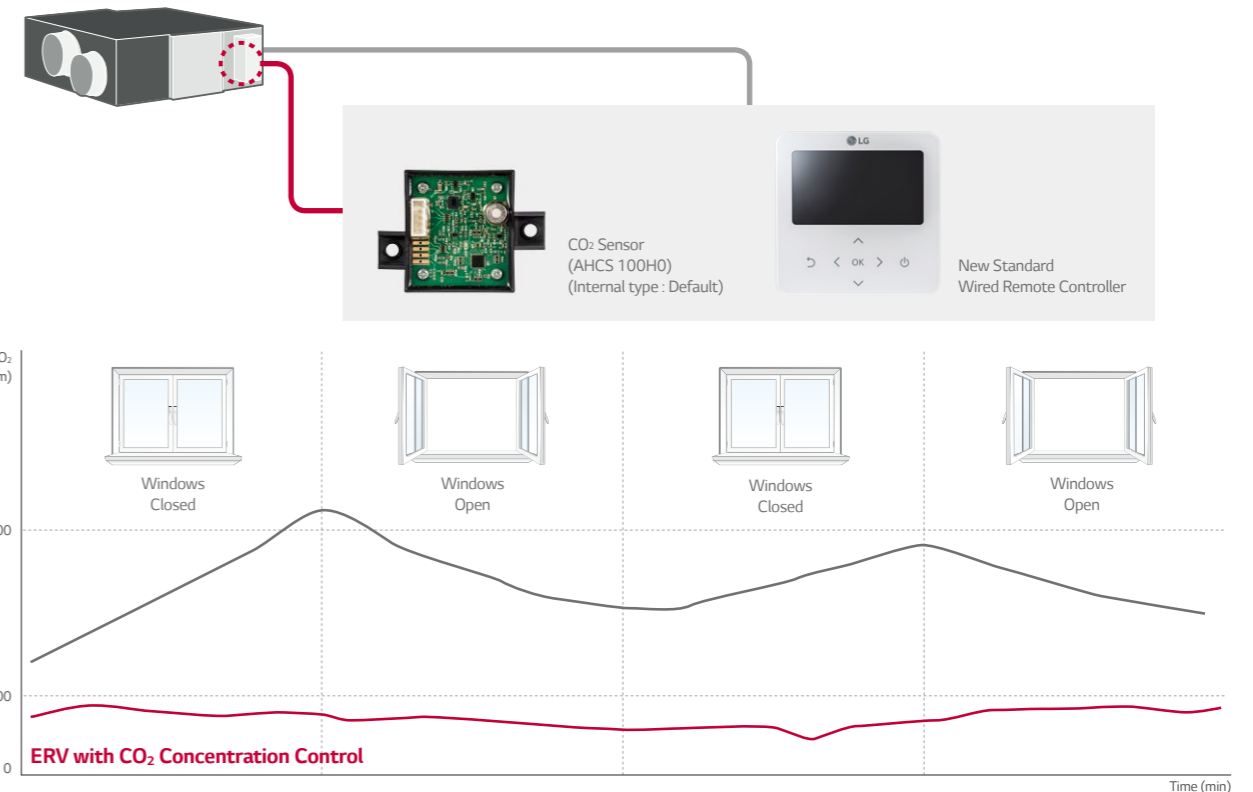

ERV

New Easy Controller

New wired remote controller is easy for usage.



Convenient!

- **Flexible display**
 - Dual display with air conditioner.
 - Zoom selected directory to increase legibility.

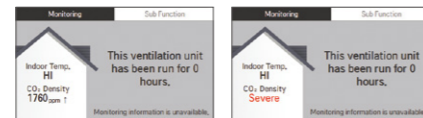

Easy!

- Navigation buttons, easy to use.
- Easy installation setting

Visible!

- Indoor CO₂ level
- Alarm for filter change / Remained time to change filters

Air Purifying System (3 Steps)

LG ERV can effectively remove the various harmful substances, such as micro dust and viruses. Possible selection of the high efficiency filter(F7) for micro dust removed.

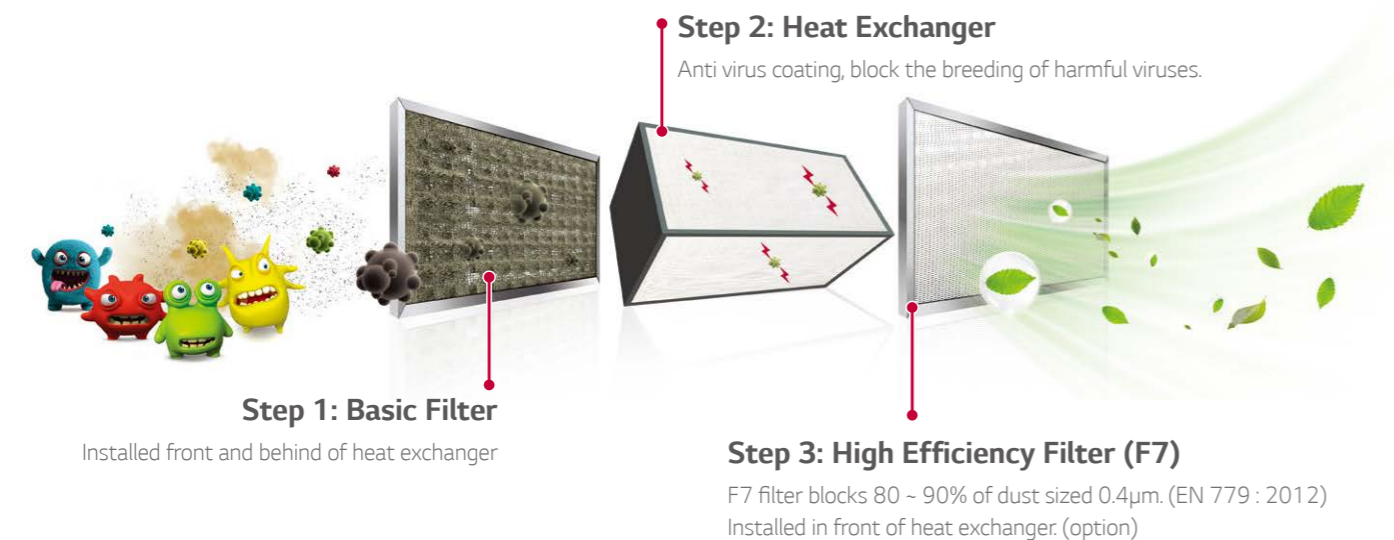

Night Time Cooling

Discharge the indoor heat in the summer night and supply cool outdoor air to indoors. so it can save energy.

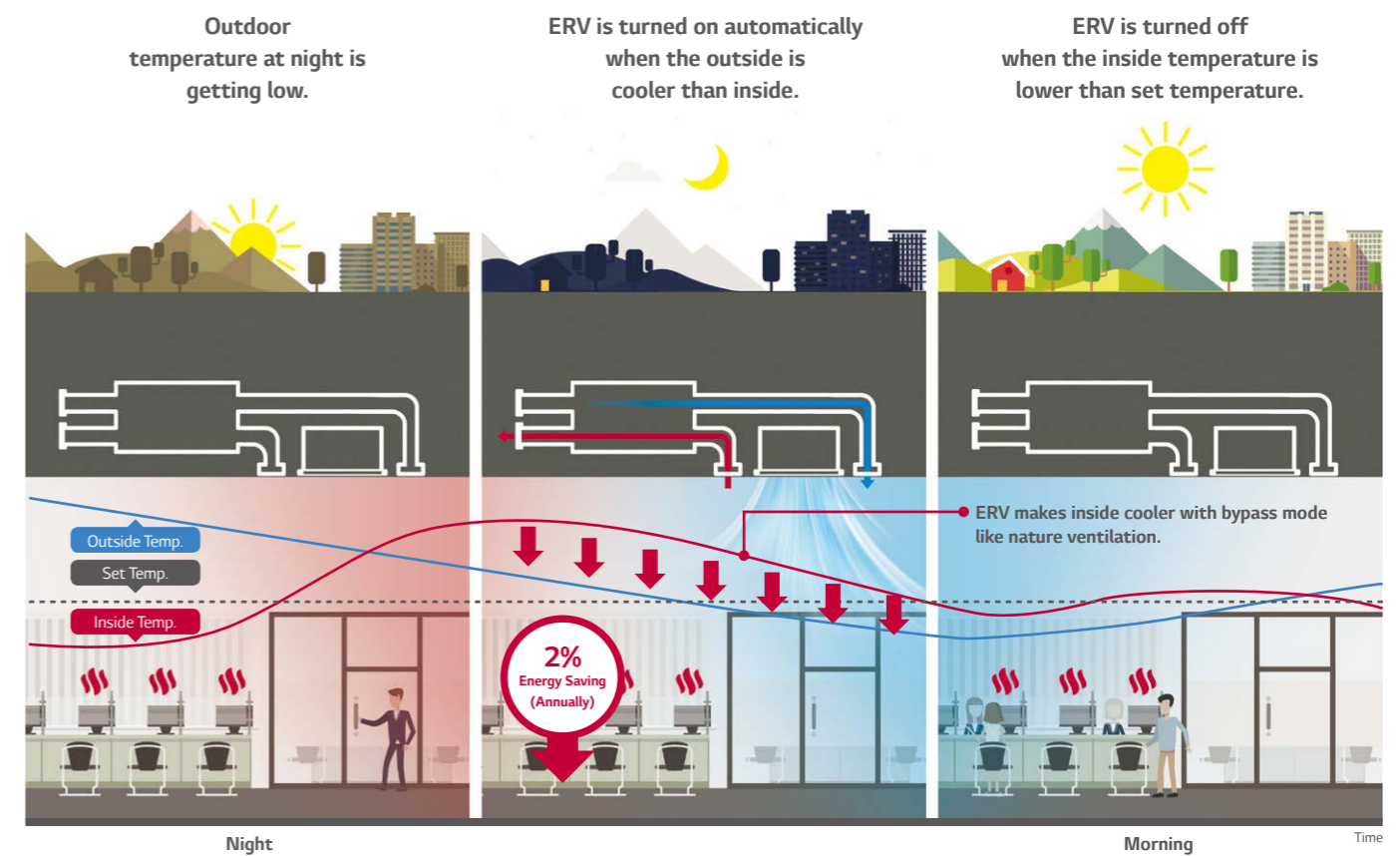

* This function is operated with 'Night Time Free Cooling' on remote controller. (with MULTI V only)
 ** Energy saving ratio Can vary with condition.
 *** Available only with Standard III

• Test Condition
 - Office (49,000 ft² / Occupancy : 30 / Area : London, UK
 - ERV (1 000 CMH) + MULTI V 4 (12 HP) Unit Combination
 - Other conditions are subject to BREEAM.
 (Building Research Establishment's Environmental Assessment Method)

VENTILATION SOLUTION SPECIFICATION

ERV

LZ-H025GBA4 / LZ-H035GBA5 / LZ-H050GBA5



Model		LZ-H025GBA4	LZ-H035GBA5	LZ-H050GBA5
Nominal Capacity	CMH (CFM)	250 (147)	350 (206)	500 (294)
Power Supply	Ø, V, Hz	1, 220 - 240, 50 - 60		
ERV mode	Step	SUPER-HIGH / HIGH / LOW		
	Current	SH / H / L	Amps	0.70 / 0.60 / 0.42
	Power Input	SH / H / L	W	97 / 78 / 52
	Air Flow	SH / H / L	CMH (CFM)	250 / 250 / 150 (147 / 147 / 88)
	External Static Pressure	SH / H / L	Pa (inWTR)	100 / 70 / 50 (0.40 / 0.28 / 0.20)
	Temperature Exchange Efficiency	SH / H / L	%	80 / 80 / 83
	Enthalpy Exchange Efficiency	Heating (SH / H / L)	%	70 / 70 / 72
		Cooling (SH / H / L)	%	66 / 66 / 68
	Noise Level (Sound Level, 1.5m)	SH / H / L	dB(A)	29 / 28 / 24
Bypass mode	Step	SUPER-HIGH / HIGH / LOW		
	Current	SH / H / L	Amps	0.70 / 0.60 / 0.42
	Power Input	SH / H / L	W	97 / 78 / 52
	Air Flow	SH / H / L	CMH (CFM)	250 / 250 / 150 (147 / 147 / 88)
	External Static Pressure	SH / H / L	Pa (inWTR)	100 / 70 / 50 (0.40 / 0.28 / 0.20)
	Noise Level (Sound Level, 1.5m)	SH / H / L	dB(A)	29 / 29 / 25
Heat Exchanger	Type	Air to Air cross flow heat exchange		
Net Weight	kg	44		
Dimension	W x H x D	1,014 x 273 x 988		
Duct work*	Qty	4		
	Size (Ø)	Ø200		
Supply Air Fan	Qty	1		
	Type	Direct-Drive (Sirocco Fan)		
Exhaust Air Fan	Qty	1		
	Type	Direct-Drive (Sirocco Fan)		
Filters (Default)	Qty	2		
	Type	Cleanable fibrous fleeces		
	Size (W x H x D)	855 x 10 x 160		
Filters (Optional)	Model	AHFT035H0		AHFT050H0
	Qty	2		2
	Type	F7		F7
	Size (W x H x D)	423.5 x 132 x 25		425 x 194 x 25
Dry Contact	Simple (1 Contact point with case)	PDRYCB000		

- Note : 1. ERV mode : Total Heat Recovery Ventilation mode
 2. * : Refer to dimensional drawings.
 3. Noise level : - The operating conditions are assumed to be standard
 - Sound measured at 1.5m below the center the body.
 - Sound level will vary depending on a range of factors such as the construction(acoustic absorption coefficient) of particular room in which the equipment is installed.
 - The sound level at the air discharge port is about 8 dB(A) higher than the unit's operating sound.
 4. Temperature and Enthalpy Exchange Efficiency at cooling Indoor Temperature : 26.5°C DB, 64.5% RH, Outdoor Temperature : 34.5°C DB, 75% RH
 5. Temperature and Enthalpy Exchange Efficiency at heating Indoor Temperature : 20.5°C DB, 59.5% RH, Outdoor Temperature : 5°C DB, 65% RH
 6. Temperature Exchange efficiency is tested at heating condition.
 7. F7 Filter is 2 pieces in 1 filter package

Premium	Standard III	Standard II	CO ₂ Sensor
PREMTA000 PREMTA000A PREMTA000B	PREMTB100	PREMTBB10	AHCS100H0 (Internal Type : Default)
PREMTBB01	PREMTB001		

LZ-H080GBA5 / LZ-H100GBA5
LZ-H150GBA5 / LZ-H200GBA5



Model		LZ-H080GBA5	LZ-H100GBA5	LZ-H150GBA5	LZ-H200GBA5
Nominal Capacity	CMH (CFM)	800 (471)	1,000 (589)	1,500 (883)	2,000 (1,177)
Power Supply	Ø, V, Hz	1, 220 - 240, 50 - 60			
ERV mode	Step	SUPER-HIGH / HIGH / LOW			
	Current	SH / H / L	Amps	2.13 / 1.75 / 1.00	2.92 / 2.38 / 1.40
	Power Input	SH / H / L	W	328 / 266 / 144	463 / 370 / 208
	Air Flow	SH / H / L	CMH (CFM)	800 / 800 / 660 (471 / 471 / 388)	1,000 / 1,000 / 800 (589 / 589 / 471)
	External Static Pressure	SH / H / L	Pa (inWTR)	160 / 100 / 50 (0.64 / 0.40 / 0.20)	160 / 100 / 50 (0.64 / 0.40 / 0.20)
	Temperature Exchange Efficiency	SH / H / L	%	82 / 82 / 83	80 / 80 / 81
	Enthalpy Exchange Efficiency	Heating (SH / H / L)	%	73 / 73 / 76	73 / 73 / 76
		Cooling (SH / H / L)	%	66 / 66 / 70	64 / 64 / 67
	Noise Level (Sound Level, 1.5m)	SH / H / L	dB(A)	40 / 36 / 32	40 / 37 / 33
Bypass mode	Step	SUPER-HIGH / HIGH / LOW			
	Current	SH / H / L	Amps	2.13 / 1.75 / 1.00	2.92 / 2.38 / 1.40
	Power Input	SH / H / L	W	328 / 266 / 144	463 / 370 / 208
	Air Flow	SH / H / L	CMH (CFM)	800 / 800 / 660 (471 / 471 / 388)	1,000 / 1,000 / 800 (589 / 589 / 471)
	External Static Pressure	SH / H / L	Pa (inWTR)	160 / 100 / 50 (0.64 / 0.40 / 0.20)	160 / 100 / 50 (0.64 / 0.40 / 0.20)
	Noise Level (Sound Level, 1.5m)	SH / H / L	dB(A)	41 / 37 / 33	44 / 40 / 36
Heat Exchanger	Type	Air to Air cross flow heat exchange			
Net Weight	kg	70			
Dimension	W x H x D	1,101 x 405 x 1,230			
Duct work*	Qty	4			
	Size (Ø)	Ø250			
Supply Air Fan	Qty	1			
	Type	Direct-Drive Sirocco			
Exhaust Air Fan	Qty	1			
	Type	Direct-Drive Sirocco			
Filters (Default)	Qty	2			
	Type	Cleanable fibrous fleeces			
	Size (W x H x D)	1,148 x 6 x 245			
Filters (Optional)	Model	AHFT100H1		AHFT100H1	
	Qty	2		4	
	Type	F7		F7	
	Size (W x H x D)	520 x 192 x 25		520 x 192 x 25	
Dry Contact	Simple (1 Contact point with case)	PDRYCB000		PDRYCB000	

- Note : 1. ERV mode : Total Heat Recovery Ventilation mode
 2. * : Refer to dimensional drawings.
 3. Noise level : - The operating conditions are assumed to be standard
 - Sound measured at 1.5m below the center the body.
 - Sound level will vary depending on a range of factors such as the construction(acoustic absorption coefficient) of particular room in which the equipment is installed.
 - The sound level at the air discharge port is about 8 dB(A) higher than the unit's operating sound.
 4. Temperature and Enthalpy Exchange Efficiency at cooling Indoor Temperature : 26.5°C DB, 64.5% RH, Outdoor Temperature : 34.5°C DB, 75% RH
 5. Temperature and Enthalpy Exchange Efficiency at heating Indoor Temperature : 20.5°C DB, 59.5% RH, Outdoor Temperature : 5°C DB, 65% RH
 6. Temperature Exchange efficiency is tested at heating condition.
 7. F7 Filter is 2 pieces in 1 filter package

Premium	Standard III	Standard II	CO ₂ Sensor
PREMTA000 PREMTA000A PREMTA000B	PREMTB100	PREMTBB10	AHCS100H0 (Internal Type : Default)
PREMTBB01	PREMTB001		

VENTILATION SOLUTION

ERV

LZ-H025GBA4



Ventilation

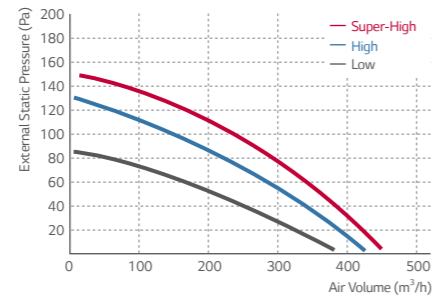

Efficiency

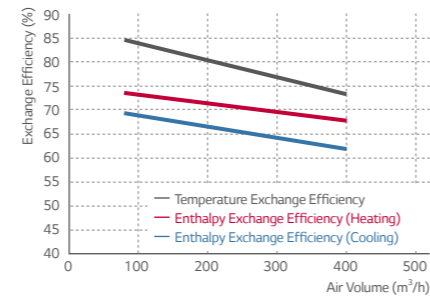

LZ-H100GBA5



Ventilation

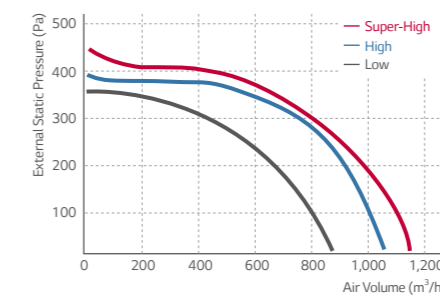

Efficiency

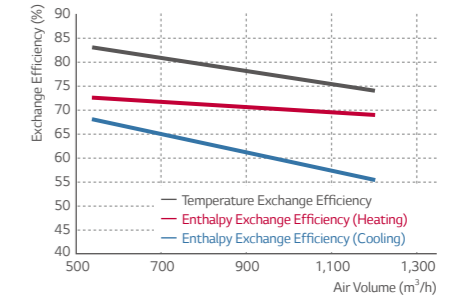

LZ-H035GBA5



Ventilation

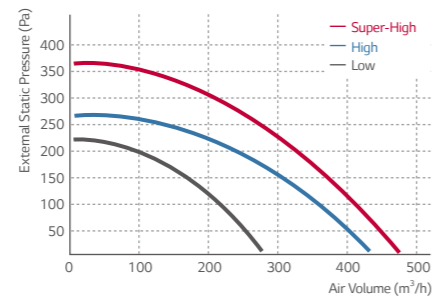

Efficiency

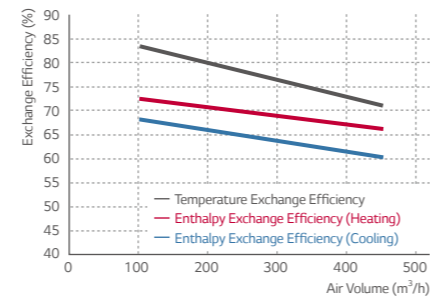

LZ-H150GBA5



Ventilation

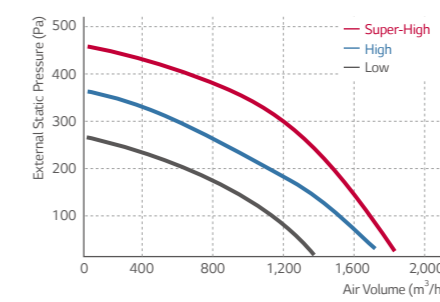

Efficiency

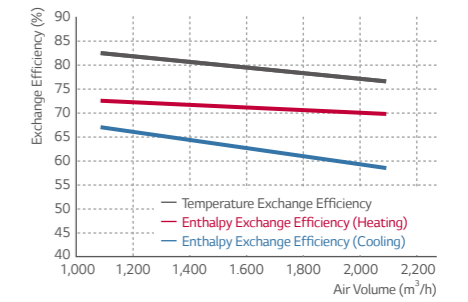

LZ-H050GBA5



Ventilation

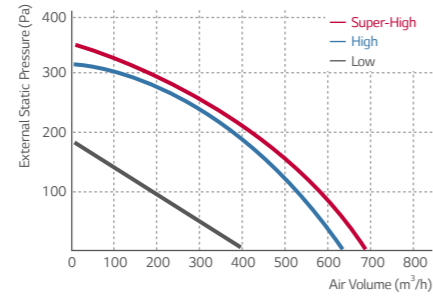

Efficiency

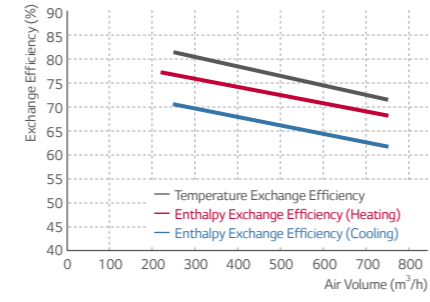

LZ-H200GBA5



Ventilation

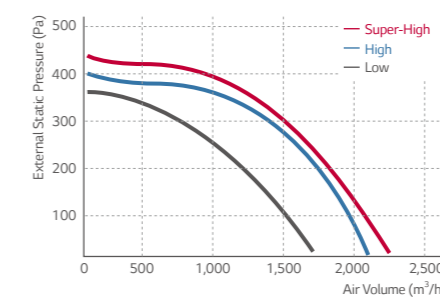

Efficiency

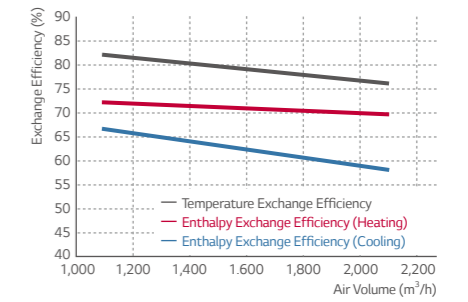

LZ-H080GBA5



Ventilation

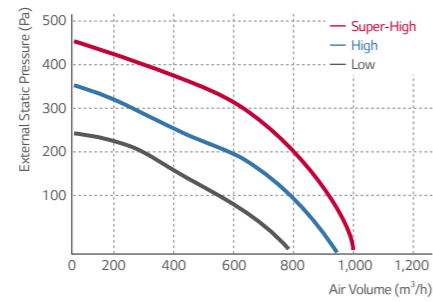

Efficiency

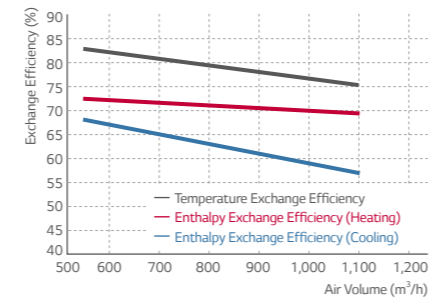

ERV WITH DX COIL

Providing Cool & Warm Fresh Air

During the summer, ERV DX can transform outdoor warm air into cool air for indoors, and it can prevent cold drafts during the winter by supplying warm air.

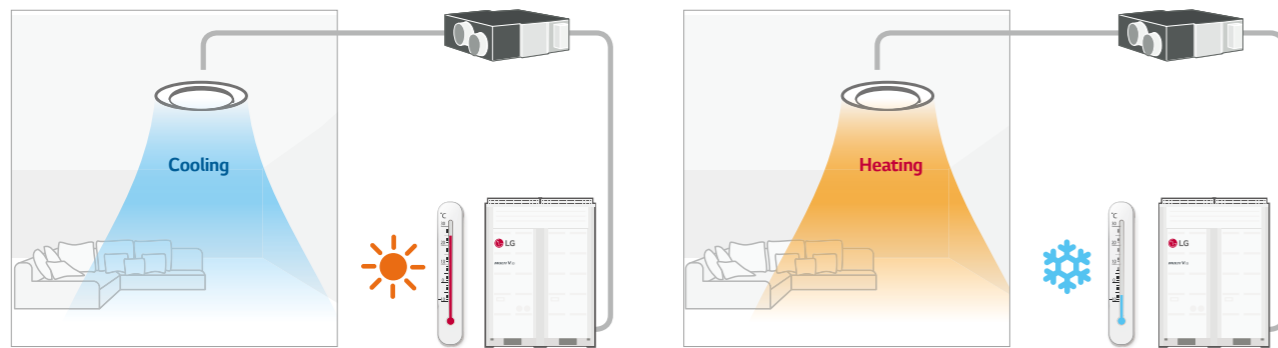

Total Air Conditioning Solution

LG ERV DX can be used as a Total Air Conditioning Solution. It can control condition of incoming air with the DX coil and humidifier for making comfortable indoor air. In the summer, LG ERV DX controls the air indoors by cooling and dehumidifying incoming air. In winter, it can provide warm air by heating and humidifying the incoming air.

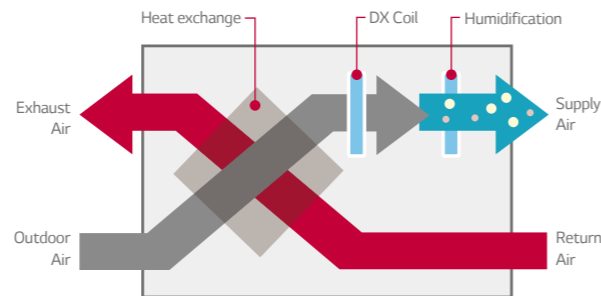

Interlocking with MULTI V

LG ERV DX can be interlocked with MULTI V. It can be controlled individually by a wired remote controller connected to MULTI V indoor units.

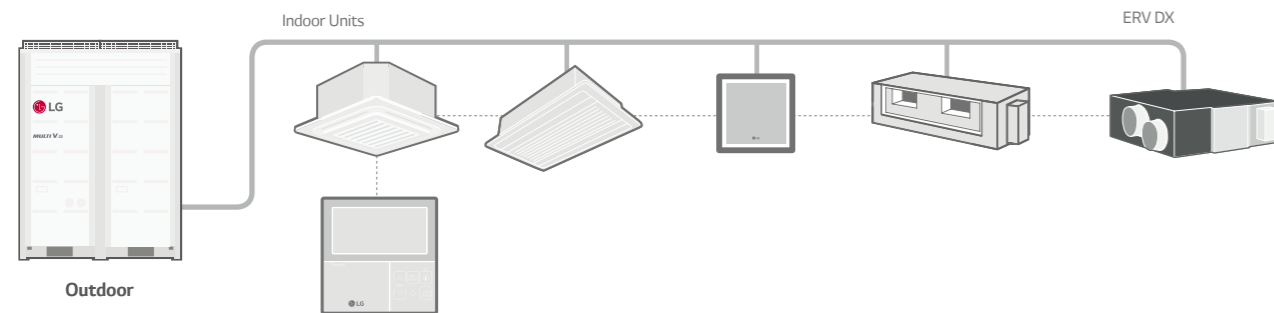

ERV WITH DX COIL

LZ-H050GXH4 / LZ-H080GXH4 / LZ-H100GXH4
LZ-H050GXN4 / LZ-H080GXN4 / LZ-H100GXN4



Model		LZ-H050GXH4	LZ-H080GXH4	LZ-H100GXH4	LZ-H050GXN4	LZ-H080GXN4	LZ-H100GXN4	
Fresh Air Conditioning Load	Cooling ¹⁾	4.93	7.46	9.12	4.93	7.46	9.12	
	Heating ²⁾	6.73	9.80	11.72	6.73	9.80	11.72	
Temperature Exchange Efficiency	SH / H / L	86 / 86 / 87	80 / 80 / 81	76 / 76 / 78	86 / 86 / 87	80 / 80 / 81	76 / 76 / 78	
	Enthalpy Exchange Efficiency	61 / 61 / 63	50 / 50 / 53	45 / 45 / 50	61 / 61 / 63	50 / 50 / 53	45 / 45 / 50	
	Heat Exchange Mode (SH / H / L)	CMH	500 / 500 / 440	800 / 800 / 640	1,000 / 1,000 / 820	500 / 500 / 440	800 / 800 / 640	1,000 / 1,000 / 820
Air Flow Rate	Bypass Mode (SH / H / L)	CMH	500 / 500 / 440	800 / 800 / 640	1,000 / 1,000 / 820	500 / 500 / 440	800 / 800 / 640	1,000 / 1,000 / 820
	Fan	External Static Pressure (SH / H / L)	Pa	160 / 120 / 100	140 / 90 / 70	110 / 70 / 60	180 / 150 / 110	170 / 120 / 80
Humidifier	System	Natural Evaporating Type						
	Amount ³⁾	kg/h	2.70	4.00	5.40			
	Pressure Feed Water	Mpa	0.02 - 0.49					
Sound Pressure	Heat Exchange Mode (SH / H / L)	dB (A)	38 / 36 / 33	39 / 37 / 34	40 / 38 / 35	39 / 37 / 35	41 / 38 / 36	41 / 39 / 36
	Bypass Mode (SH / H / L)	dB (A)	39 / 37 / 34	40 / 38 / 35	40 / 38 / 35	39 / 37 / 35	41 / 38 / 36	41 / 39 / 36
Refrigerant		R410A						
Power Supply	Ø / V / Hz	1 / 220-240 / 50, 60						
Power Input (Nominal)	Heat Exchange Mode (SH / H / L)	kW	0.25 / 0.20 / 0.15	0.42 / 0.35 / 0.25	0.48 / 0.42 / 0.27	0.25 / 0.20 / 0.15	0.42 / 0.35 / 0.25	0.48 / 0.42 / 0.27
	Bypass Mode (SH / H / L)	kW	0.25 / 0.20 / 0.15	0.42 / 0.35 / 0.25	0.48 / 0.42 / 0.27	0.25 / 0.20 / 0.15	0.42 / 0.35 / 0.25	0.48 / 0.42 / 0.27
Nominal Running Current (RLA)	Heat Exchange Mode (SH / H / L)	A	1.5 / 1.3 / 1.0	2.5 / 2.0 / 1.5	3.6 / 3.2 / 2.3	1.5 / 1.3 / 1.0	2.5 / 2.0 / 1.5	3.6 / 3.2 / 2.3
	Bypass Mode (SH / H / L)	A	1.5 / 1.3 / 1.0	2.5 / 2.0 / 1.5	3.6 / 3.2 / 2.3	1.5 / 1.3 / 1.0	2.5 / 2.0 / 1.5	3.6 / 3.2 / 2.3
Dimensions	W x H x D	mm	1,667 x 365 x 1,140			1,667 x 365 x 1,140		
Net Weight		kg	105			98		
	Liquid	mm	Ø6.35			Ø6.35		
Piping Connection	Gas	mm	Ø12.7			Ø12.7		
	Water	mm	Ø6.35			-		
	Drain (Outer Diameter)	mm	Ø25.4			Ø25.4		
Connection Duct Diameter	mm		Ø250			Ø250		
Remote Controller		Refer to the below Wired Remote Controller table						
Dry Contact	Simple (1 Contact Point with Case)		PDRYCB000					
	2 Contact Point		PDRYCB400					
	For Thermostat (On-Off / Mode / Fan Speed)		PDRYCB300					
	Modbus Communication		PDRYCB500					
Filters (Optional)	Mode	-	AHFT100H0					
	Qty	EA	2					
	Type	-	F7					
	Size (W x H x D)	mm	520 x 192 x 25					

Note :

- Cooling Capacity Test condition - Indoor temperature : 27°C DB, 19°C WB / Outdoor temperature : 35°C DB
- Heating Capacity Test condition - Indoor temperature : 20°C DB / Outdoor temperature : 7°C DB, 6°C WB
- Humidifying capacity is based on the following conditions - Indoor temperature : 20°C DB, 15°C WB / Outdoor temperature : 7°C DB, 6°C WB
 - * Cooling and heating capacities are based on the following conditions. - Fan is based on High and Super-high. The figures in the parenthesis indicate the heat reclaimed from the heat recovery ventilator.
 - * The operating sound measured at the point 1.5 m below the center of the unit is converted to that measured at an anechoic chamber built in accordance with the KS B 6879 conditions.
 - * The actual operating sound varies depending on the surrounding conditions (near running unit's sound, reflected sound and so on) and is normally higher than this value.
 - * Air flow rate can be changed over to low mode or high mode.
 - * The specifications, designs and information here are subject to change without notice.
 - * This product contains Fluorinated Greenhouse Gases. (R410A)
- F7 Filter is 2 pieces in 1 filter package

Premium	Standard III	Standard II	CO ₂ Sensor			
PREMTA000 PREMTA000A PREMTA000B	PREMTB100	PREMTBB10	PREMTBB01	PREMTB001	PES-CORV0 (External Type)	AHCS100H0 (Internal Type : Default)

COMPATIBILITY TABLE

• : Compatible ▲ : Need wired remote controller / IR receiver X : Not compatible

Controller		Product														
		Premium	Standard III			Standard II		Simple		Simple for Hotel		Wireless	Dry Contact			Wi-Fi
Product		PREMTA000 PREMTA00A PREMTA00B	PREMTB10	PREMTB100	PREMTB801	PREMTB001	PQRCVCLQ	PQRCVCOQW	PQRCHAQ	PQRCHAQW	PQWRHQFDB	Simple Dry Contact PDRYCB000	2 points Dry Contact PDRYCB400	Dry Contact for Thermostat PDRYCB300	For Modbus PDRYCB500	LG-IR-WF-1
Ceiling Mounted Cassette	4 Way	•	•	•	•	•	•	•	•	•	•	•	•	•	•	•
	2 Way / 1 Way	•	•	•	•	•	•	•	•	•	•	•	•	•	•	•
Ceiling Concealed Duct	High Sensible	•	•	•	•	•	•	•	•	▲	•	•	•	•	•	•
	High Statics Mid Statics	•	•	•	•	•	•	•	•	▲	•	•	•	•	•	•
	Low Statics	•	•	•	•	•	•	•	•	▲	•	•	•	•	•	•
FAU (Fresh Air Intake Unit)	Built-in	•	•	•	•	•	•	•	•	•	•	•	•	•	•	•
	ARNU-Z4	•	•	•	•	•	•	•	•	▲	•	•	•	•	•	•
Convertible & Ceiling Suspended Unit	ARNU-A4	•	•	•	•	•	•	•	•	•	•	•	•	•	•	•
	ARNU-A4	•	•	•	•	•	•	•	•	•	•	•	•	•	•	•
Console	ARNU-A4	•	•	•	•	•	•	•	•	•	•	•	•	•	•	•
	ARNU-U4	•	•	•	•	•	•	•	•	•	•	•	•	•	•	•
Floor Standing Unit	ARNU-A4	•	•	•	•	•	•	•	•	•	•	•	•	•	•	•
	ARNU-U4	•	•	•	•	•	•	•	•	•	•	•	•	•	•	•
	ARNU-A4	•	•	•	•	•	•	•	•	•	•	•	•	•	•	•
Wall Mounted Unit	ARNU-A4	•	•	•	•	•	•	•	•	•	•	•	•	•	•	•
	ARNU-A4 ¹⁾	•	•	•	•	•	•	•	•	•	•	•	•	•	•	•
	ARNU-L4	•	•	•	•	•	•	•	•	•	•	•	•	•	•	•
HYDRO KIT ²⁾	ARNU-A4	•	•	•	•	•	•	•	•	•	•	•	•	•	•	•
	ARNU-A4	•	•	•	•	•	•	•	•	•	•	•	•	•	•	•
Ventilation	Energy Recovery Ventilator	•	•	•	•	•	•	•	•	•	▲	•	•	•	•	•
	Energy Recovery Ventilator with DX coil	•	•	•	•	•	•	•	•	•	▲	•	•	•	•	•
AHU Communication Kit	•	•	•	•	•	•	•	•	•	•	•	•	•	•	•	•

1) Artcool Mirror : Mirror (R) / Silver (V) / White (W)
2) It has a separate remote controller

• : Compatible ▲ : Need wired remote controller / IR receiver X : Not compatible

Model		Controller														
		Premium	Standard III			Standard II		Simple		Simple for Hotel		Wireless	Dry Contact			Wi-Fi
Product		PREMTA000 PREMTA00A PREMTA00B	PREMTB10	PREMTB100	PREMTB801	PREMTB001	PQRCVCLQ	PQRCVCOQW	PQRCHAQ	PQRCHAQW	PQWRHQFDB	Simple Dry Contact PDRYCB000	2 points Dry Contact PDRYCB400	Dry Contact for Thermostat PDRYCB300	For Modbus PDRYCB500	LG-IR-WF-1
H-Inverter	Ceiling Mounted Cassette	•	•	•	•	•	•	•	•	•	•	•	•	•	•	•
	Ceiling Concealed Duct	•	•	•	•	•	•	•	•	•	•	•	•	•	•	•
	Ceiling Suspended Unit	•	•	•	•	•	•	•	•	•	•	•	•	•	•	•
Standard Inverter	Ceiling Mounted Cassette	•	•	•	•	•	•	•	•	•	•	•	•	•	•	•
	High	•	•	•	•	•	•	•	•	•	•	•	•	•	•	•
	Ceiling Concealed Duct	•	•	•	•	•	•	•	•	•	•	•	•	•	•	•
Console	Mid	•	•	•	•	•	•	•	•	•	•	•	•	•	•	•
	Low	•	•	•	•	•	•	•	•	•	•	•	•	•	•	•
	Ceiling Suspended Unit	•	•	•	•	•	•	•	•	•	•	•	•	•	•	•
Wall Mounted Unit	ARNU-A4	•	•	•	•	•	•	•	•	•	•	•	•	•	•	•
	ARNU-U4	•	•	•	•	•	•	•	•	•	•	•	•	•	•	•
	ARNU-A4	•	•	•	•	•	•	•	•	•	•	•	•	•	•	•
Floor Standing Unit	ARNU-A4	•	•	•	•	•	•	•	•	•	•	•	•	•	•	•
	ARNU-U4	•	•	•	•	•	•	•	•	•	•	•	•	•	•	•
	ARNU-A4	•	•	•	•	•	•	•	•	•	•	•	•	•	•	•
Convertible & Ceiling Suspended Unit	ARNU-A4	•	•	•	•	•	•	•	•	•	•	•	•	•	•	•
	ARNU-A4	•	•	•	•	•	•	•	•	•	•	•	•	•	•	•
	ARNU-U4	•	•	•	•	•	•	•	•	•	•	•	•	•	•	•
Console	ARNU-A4	•	•	•	•	•	•	•	•	•	•	•	•	•	•	•
	ARNU-U4	•	•	•	•	•	•	•	•	•	•	•	•	•	•	•
	ARNU-A4	•	•	•	•	•	•	•	•	•	•	•	•	•	•	•
Wall Mounted Unit	ARNU-A4	•	•	•	•	•	•	•	•	•	•	•	•	•	•	•
	ARNU-A4 ¹⁾	•	•	•	•	•	•	•	•	•	•	•	•	•	•	•
	ARNU-L4	•	•	•	•	•	•	•	•	•	•	•	•	•	•	•
HYDRO KIT ²⁾	ARNU-A4	•	•	•	•	•	•	•	•	•	•	•	•	•	•	•
	ARNU-A4	•	•	•	•	•	•	•	•	•	•	•	•	•	•	•
	ARNU-U4	•	•	•	•	•	•	•	•	•	•	•	•	•	•	•
Ventilation	Energy Recovery Ventilator	•	•	•	•	•	•	•	•	•	•	•	•	•	•	•
	Energy Recovery Ventilator with DX coil	•	•	•	•	•	•	•	•	•	•	•	•	•	•	•
	ARNU-A4	•	•	•	•	•	•	•	•	•	•	•	•	•	•	•

VENTILATION SOLUTION